

Selecting the perfect silicone for your formulation

Silicone chemistry is playing an increasingly important role in modern personal care and cosmetic formulations. A unique and multifunctional set of properties combine to ensure silicones stay at the top of the formulator's toolkit, delivering superior aesthetics and unmatched, cost-effective, sensory benefits. Silicones are available in numerous formats providing the formulator with endless possibilities to introduce luscious softness and shine to hair care products, luxurious texture to skin preparations with excellent spreading, long-lasting and protecting effects.

Silicon (Si) is the second most abundant element on Earth; it chemically bonds to oxygen, as silica, that is SiO₂, the natural basis of sand. Often manufacturers and consumers mistakenly believe that silicones are oil-derived petrochemicals, whereas, they are actually synthetic products prepared from sand or quartz, among the most abundant minerals on earth. Silicone is the term used for materials in which silicon is bonded to oxygen in a linear polymeric matrix. The Si-O (silicon-oxygen) bond and Si-C (silicon-carbon) bond allow



freedom of rotation, which enables these molecules to adopt the lowest energy configuration at interfaces. This leads to ultra low surface tension values compared to organic polymers. With these unique properties, silicones make an ideal choice for a multitude of personal care applications.

Volatile silicone fluids

Volatile silicone fluids consist of cyclic and linear molecules having a viscosity of less than 5 cst. The term of cyclomethicone refers to a series of cyclic silicone compounds (Fig. 1). Table 1 illustrates the heat of vaporisation for several compounds; cyclopentasiloxane takes less energy to evaporate compared to water and ethanol.

Cyclomethicone with low heat of vaporisation and low viscosity imparts a transient, non-greasy and non-cooling

effect on skin. It helps to improve the rub-in and spreadability of creams and lotions. Cyclomethicone can be used as a volatile carrier and is compatible with a wide range of cosmetic ingredients. Cyclomethicone may be used alone or blended with other cosmetic fluids to provide a liquid base for a variety of cosmetic ingredients. It features good solubility in most anhydrous alcohols and in many cosmetic solvents. Cyclomethicone and dimethicone (<5 cst) have been widely used in antiperspirants, deodorants, hair sprays, cleansing creams, skin creams (Formulation 1), lotions and stick products, bath oils, sunscreens, shaving products and makeup products. Due to its volatile profile, cyclomethicone must be added to formulations at temperatures below 60 °C.

Non volatile dimethicones

Dimethicone (Fig. 2) is the INCI name for a series of basic silicones used as the base fluid in a many personal care formulations. These inert polymers are optically clear,

Figure 1: Molecular structure of cyclopentasiloxane.

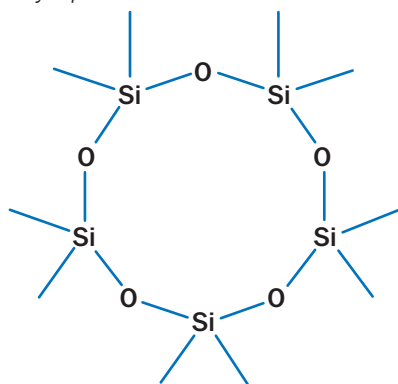
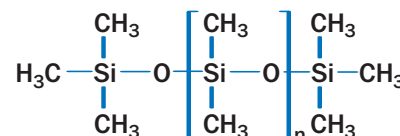

Table 1: Heat of vaporisation.

Compound	Heat of vaporisation (cal/g)
Water	539
Ethanol	210
Cyclopentasiloxane	31

Figure 2: Molecular structure of dimethicone.



Formulation 1: Magic Water Bead Cream.

Phase	INCI name	Dosage (%)
A	Aqua	78.40
	Sodium Chloride	1.00
	Glycerin	5.00
B	Cyclopentasiloxane (and) PEG/ PPG-18/ 18 Dimethicone	5.50
	Cyclopentasiloxane (and) Cyclohexasiloxane	5.00
	Dimethicone (and) Dimethicone/ Vinyl Dimethicone Crosspolymer	1.50
	Dimethicone	3.00
C	Methylparaben (and) Ethylparaben (and) Propylparaben (and) Butylparaben (and) Phenoxyethanol	0.50

Procedure

Mix phase A well. Mix phase B separately. Add phase A slowly into phase B while stirring. Add phase C into bulk and mix well.

Table 2: Draves wetting.

Compound	Molecular weight	Wetting time (seconds)
A	632	7
B	701	8
C	1240	10
D	1917	16

odourless and non-flammable. They are often referred to as silicone oil, dimethyl polysiloxane, and polydimethylsiloxane, and take viscosities within a broad range from 5 cst to 1 million cst. Dimethicones with low viscosity (5 to 50 cst) and medium viscosity (50 to 1000 cst) are widely used in skin creams (Formulation 1), skin lotions, suntan lotions, bath oils and hair care products. High-viscosity dimethicones (60,000 to 100,000 cst) are commonly used in hair care products. Dimethicone's low surface tension enables it to spread thinly and evenly along the hair shaft producing an even-looking conditioning effect. When applied to the hair they quickly form protective films, locking in water, to optimise strength and prevent premature wash-out of hair dyes and tints. In skin formulations they form smooth, level films, act as effective emollients and help spread other ingredients and actives. Non-volatile dimethicones are easy to incorporate via the oil phase, under mild heating, often with other emulsifying waxes such as cetearyl alcohol.

Dimethiconol blends

Dimethiconol, also referred to as silicone gum (Fig. 3), is a polymer similar to dimethicone where two chain-end methyl groups have been replaced by hydroxyl (-OH) groups. Two dimethiconol blends were developed, known by their CTFA designation (i) Dimethicone (and) Dimethiconol; (ii) Cyclomethicone (and) Dimethiconol. They are dispersions of very high molecular weight silicone gum in

dimethicone or cyclomethicone. They offer a controlled conditioning effect to leave unhealthy, damaged hair looking and feeling fantastic. As the basis of serum-type leave-in conditioners they ensure hair feels silky-soft and velvety with excellent shine characteristics.

Dimethiconol's unique properties are widely used in hair cuticle coats offering notable respite from problems such as split-ends (Formulation 2). In this hair cuticle formulation, the volatile cyclopentasiloxane functions as a temporary, transient conditioner. As it slowly evaporates, it improves the wet combing of hair to leave gloss-enhancing non-volatile dimethiconol. This system improves dry combing and provide silkiness feel on hair after application.

Silicone surfactants

Silicone surfactants are synthesised to contain both silicone and water-soluble groups within the same molecule. The result is a series of compounds with varying and controllable levels of solubility in oil, water and silicone. One of the common silicone surfactant is dimethicone copolyol.

Dimethicone copolyol is an amphiphilic compound designed to assist in the preparation of water-in-silicone or silicone-in-water emulsions. There are various types of dimethicone copolyol in the market, offering an array of HLB values (Table 3), arising due to the presence of two or more mutually insoluble groups. Typically, a low HLB, silicone-soluble (siliphilic) siloxane backbone coupled with a higher HLB, more water-soluble (hydrophilic) polyoxyalkylene component. Commonly, either polyethylene glycol (PEG), polypropylene glycol (PPG) or both are grafted onto a polydimethylsiloxane backbone in varying ratios.

Cyclopentasiloxane (and) PEG/ PPG-18/ 18 Dimethicone (Fig. 4) is one type of the dimethicone copolyol widely used to prepare water-in-silicone emulsions

Figure 3: Molecular structure of dimethiconol.

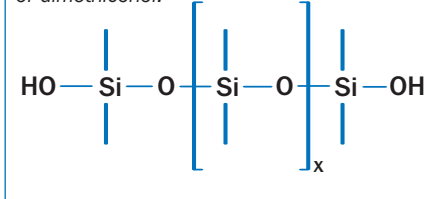
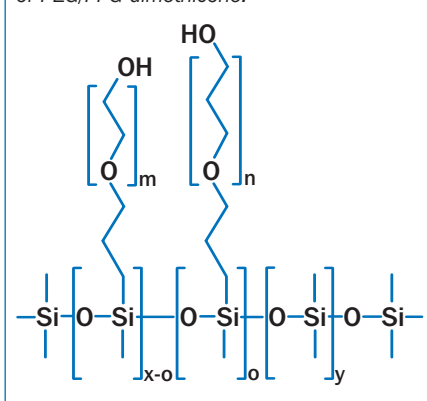

Figure 4: Molecular structure of PEG/PPG dimethicone.



commonly found in antiperspirant, skin care and colour cosmetic formulations. The material's low surface tension and effective wetting properties serve to provide a unique and gentle skin-feel while stabilising the emulsion.

Wetting is a surface effect to characterise the behaviour of a liquid droplet deposited onto a solid/liquid substrate. For example, a water droplet placed onto a plastic sheet will form a tight sphere indicating poor wetting effect. If a wetting agent is then added to the water, the droplet will not form a sphere but spread-out across the surface of plastic sheet. The Draves test is an established method to determine wetting effect; it measures and compares the time taken for a cotton 'skein' to sink into a test solution, at a prescribed temperature. The shorter the time, the better wetting agent performs. This test uses a 0.1% solution of dimethicone copolyol (Table 2).

Overall, lower molecular weight PEG/PPG polymers offer faster wetting properties compared to high molecular weight counterparts. This means that a rapid wetting effect can be achieved by appropriate selection of a dimethicone copolyol's molecular weight.

Lowering surface tension is one of the major properties of silicone surfactant. Fatty components of a molecule, rich in methylene groups (-CH₂-), limit the surface tension within a range around 30 dynes/cm². Silicone surfactants, however with a predominance of methyl groups (-CH₃), reduces achievable surface tension at a much lower level in the region of 20 dynes/cm².

Table 3: HLB Value of dimethicone copolyols.

No.	INCI	HLB value	Type of emulsion
1	Cyclopentasiloxane (and) PEG/PPG 18/18 Dimethicone	2	Water-in-silicone
2	PEG-12 Dimethicone	13	Silicone-in-water
3	PEG-10 Dimethicone	4-5	Water-in-silicone

Formulation 2: Silky Hair Cuticle Coat.

Phase	INCI name	Dosage (%)
A	Cyclopentasiloxane (and) Dimethiconol	60.00
	Cyclopentasiloxane	40.00
Procedure Add ingredients into bulk and mix well.		

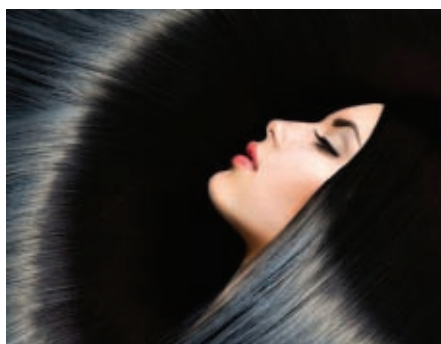
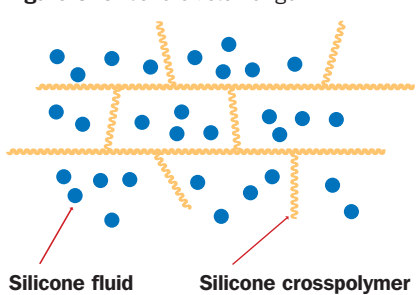

Figure 5: Silicone elastomer gel.



PEG/PPG dimethicone is used as an emulsifier in the preparation of water-in-oil and silicone-in-water emulsions. It can be used to prepare products that contain low concentrations of wax and a high concentration of water offering creams and lotions with a light and easy-spreadable skin feel. PEG/PPG dimethicone can easily structure itself, along the Si-O-Si bonds, to adopt the lowest free energy state. This enables the production of emulsions with a usefully low free energy thereby providing enhanced stability. A high surface activity offers other advantages compare to conventional w/o emulsifiers. For instance, water-in-silicone emulsions prepared with silicone emulsifiers can be produced using cold-processing techniques. This emulsifier route is widely used in colour cosmetic formulations (Formulation 3) as it improves the spreadability and levelling of colour pigment.

PEG/PPG dimethicone should be added and mixed into the silicone phase or oil phase in the preparation of silicone-in-water emulsion or water-in-oil emulsions. For ease it is ideal to prepare the water phase in a separate tank. Electrolyte such as sodium chloride should be pre-dissolved into the water phase to viscosify and help develop a stable emulsion. Add the water phase slowly into the silicone phase or oil phase to ensure complete and uniform emulsification. Mix with a high turbulence mechanical mixer at high speed. Continue high shear mixing for 10-30 minutes to generate small particle size distribution and homogenise if necessary. No heat is required during emulsification.

Silicone elastomer gel

In today's cosmetic market, consumers demand highly effective products with perfect sensory profiles, especially from high-end brands. Silicone elastomer gels (Fig. 5), also known as silicone crosspolymers, provide an exceptionally desirable skin-feel for the most innovative and flawless personal care developments. They provide a dry, non-greasy, yet silky-smooth skin-feel while absorbing quickly onto the skin. Silicone elastomers are based on crosslinked dimethicone and

supplied in the form of swollen gels containing various silicones such as cyclomethicone or dimethicone. The INCI name of silicone elastomer often contains the word 'crosspolymer'. This specified INCI name for silicone elastomer was given during 'Organosilicone Nomenclature Conventions' issued August 13, 1999.

Silicone fluid has no crosslinking potential hence the molecule backbone is highly 'flexible' and has a high freedom of rotation meaning silicones remain in liquid form, even at high molecular weights. By contrast, these elastomers have limited degrees of rotation due to a crosslinked structure, the key determinant of the polymers properties; a high crosslinked

density increases the stiffness/hardness of the crosspolymer. There are many types of crosspolymer in the market, existing in the form of elastomer gels, powders, emulsions or surfactants.

Silicone elastomer gel is used as a thickening agent, often without heating, in the preparation of water-in-silicone formulations. They can act as stabilising agents due to their inherent compatibility with a variety of lipophilic active ingredients, for example, perfumes, UV filters, anti-ageing actives. They provide silky, smooth results and reduce the tackiness of a given formulation. They are widely used in skin care, hair care, colour cosmetic, antiperspirant and sunscreen formulation. Furthermore, crosspolymer films serve to develop a layer in which perfumes or active ingredients can be contained, perfect to deliver controlled release characteristics and provide long-lasting effects. These polymers also can serve to temporarily ameliorate unsightly fine wrinkles, thus providing a smoother skin appearance.

Formulation 3 illustrates the use of a silicone elastomer gel (BRB SG 506-Dimethicone (and) Dimethicone/Vinyl Dimethicone Crosspolymer) in a modern

Formulation 3: Radiant CC Cream.

Phase	INCI name	Dosage (%)
A	Iron Oxides (C.I. 77492) (and) Cyclopentasiloxane (and) PEG/PPG-18/18 Dimethicone (and) Triethoxycaprylylsilane (and) Tocopheryl Acetate	0.18
	Iron Oxides (C.I. 77491) (and) Cyclopentasiloxane (and) PEG/PPG-18/18 Dimethicone (and) Triethoxycaprylylsilane (and) Tocopheryl Acetate	0.23
	Iron Oxides (C.I. 77499) (and) Cyclopentasiloxane (and) PEG/PPG-18/18 Dimethicone (and) Triethoxycaprylylsilane (and) Tocopheryl Acetate	0.04
	Cyclopentasiloxane	4.00
	Dimethicone	8.00
	Ethylhexyl Methoxycinnamate	5.00
	Titanium Dioxide	6.00
	Talc	2.00
	Mica	2.50
	Cyclopentasiloxane (and) PEG/ PPG 18/18 Dimethicone	10.00
Dimethicone (and) Trimethylsiloxysilicate	2.00	
B	Pentaerythrityl Tetraistearate (and) Distearidmonium Hectorite (and) Propylene Carbonate	3.00
	Dimethicone (and) Dimethicone/ Vinyl Dimethicone Crosspolymer	7.00
C	Aqua	46.25
	Glycerin	2.00
	Sodium Chloride	1.00
D	Methylparaben (and) Ethylparaben (and) Propylparaben (and) Butylparaben (and) Phenoxyethanol	0.80

Procedure

Add phase A into bulk. Homogenise well. Make sure all powder material is well dispersed. Then, add in phase B. Homogenise well. Prepare phase C in a separate beaker. Slowly add phase C into combined phase AB (Viscosity will increase gradually). Add in phase D and mix well.

CC cream formulation, an important development trend in Asia. It can be challenging to the formulator to develop a stable product with a reasonable concentration of colour pigment and silicone fluid. That cited formulation provides a non-greasy skin feel, silky and pleasant touch during and after application. Silicone elastomer gels can also be used in other colour cosmetics such as lipsticks and all types of foundation.

Silicone elastomers can be added and dispersed into either the silicone phase or oil phase prior to emulsification, alternatively it can be post-added to emulsion. For ease of use, its viscosity may be reduced by pre-blending with dimethicone or cyclomethicone.

Silicone resins

Silicone resins can be classified as silicone silicates taking their structural and performance chemistry from both systems; they have a three dimensional silicate structure which is highly crosslinked coupled with a high molecular weight. One of the good examples of silicone resins is siloxysilicates (Fig. 6). These special compounds dry on the skin to form a sensory film and are often formulated with other silicone fluids as plasticisers. They are excellent water resistant additives with notable non-transfer properties that hold pigments in place for enhanced performance. They prevent particle agglomeration and maintain the free-flowing characteristics in loose powder products. They can also act as a plasticiser and modify the hardness/brittleness of other organic resins. They are increasingly incorporated in sunscreens, deodorants, lipsticks, mascaras and foundations.

In skin care formulations, they develop long-lasting protective films to creams, baby creams, insect repellents and sunscreen products. In hair care formulation, silicone resins provide volume and body, while imparting humidity resistance to prevent straightened hair from relaxing.

Silicone emulsions for hair care

The global hair care products industry remains bullish about its growth prospects over the coming period, with emphasis on product innovation coupling superlative performance and the inclusion of natural ingredients. Conditioning and moisturising remain the key elements that hair care producers focus on.

Hair damage is an inevitable fact of life. Chemical treatments such as bleaching and coloration, hair ageing, heat styling, environment and changes in hormones all

Figure 6: Molecular structure of siloxysilicates.

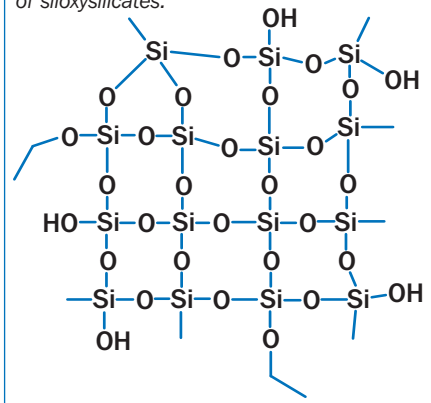

act to destroy the natural sheen and drape, leaving hair looking dull and unhealthy. Conditioning is a multifaceted expression encompassing among other properties, easy to comb character when wet as well as dry, healthy looking appearance, shine, softness and manageability. Specialty silicones can offer supreme conditioning and moisturisation that repairs and restores smoothness, shine and manageability.

Silicone and cationic polymer (e.g polyquats, guar gums) combinations are well documented as superior conditioning agents for hair. There are many types of silicones commonly used in hair care applications. As silicone fluids are not soluble in either water or organic oil, they become a major challenge to incorporate into aqueous systems. Silicone emulsions have been developed to overcome this hurdle and enable easy incorporation of silicone without temperature and with low shear. This route ensures the silicone particle size distribution can be optimised for both performance and stability in the final preparation.

Silicone emulsions based on high molecular weight of dimethiconol have excellent compatibility in aqueous solutions. In addition, these emulsions are easy to handle, and improve dispersion and distribution of silicone on the hair. For example, a silicone emulsion with CTF A designation of dimethiconol (and TEA-dodecylbenzenesulfonate, together



Figure 7: Molecular structure of amodimethicone.

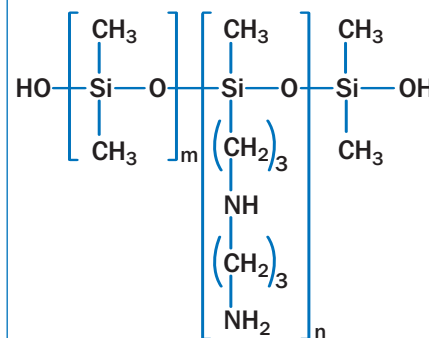

with guar gum, has been used in 2 in 1 shampoos to provide the conditioning effect. This silicone emulsion incorporates 1 million cst dimethiconol dispersed in a surfactant system. In shampoos, it improves wet and dry combing, and imparts a slippery and soft feel to the hair.

Another good example is amodimethicone emulsion. Amodimethicone (Fig. 7) is a cationic silicone which contains the amino functional group on the backbone of polydimethylsiloxane, replacing some of the methyl functional groups. Amodimethicone has a net positive charge on the nitrogen atom as a function of pH. It provides more substantive conditioning benefits and been used in both leave-in and rinse-off conditioners. The amino group provides a slick softening to hair and aids combability.

Conclusion

In today's market, the majority of personal care products contain a certain level of silicone. Their versatility and aesthetic characteristics make them a useful 'go-to' ingredient for every kind of personal care application from make up to sunscreens, face, body, antiperspirant and hair care. They find application spanning all brand lines from the simplest, cost effective shampoo for everyday use to class leading and innovative anti-ageing serums. By selecting the right silicone for your formulation, a great sensory profile and effective product aesthetic is easily achieved to fulfil the most demanding consumer requirements.

References

- 1 Houben R, Prinssen B. Silicone crosspolymers: customizing sensory feel. *Personal Care* 2011; **12** (6): 33-3.
- 2 <http://www.rsc.org/chemistryworld/podcast/CIEcompounds/transcripts/silicones.asp>
- 3 <http://www.br-b-international.com/silicones/market/personal-care>
- 4 <http://sehsc.americanchemistry.com/What-Are-Silicones>